



Hilti HIT-CT 1 with HIT-V

Injection mortar system	Benefits
 <p>Hilti HIT-CT 1 330 ml foil pack (also available as 500 ml foil pack)</p>  <p>Static mixer</p>  <p>HIT-V(-F) rods HIT-V-R rods HIT-V-HCR rods</p>	<ul style="list-style-type: none"> - Hilti Clean technology (clean-Tec) - Environmentally and user friendly: clean of critical hazardous substances - suitable for non-cracked concrete C 20/25 to C 50/60 - suitable for dry and water saturated concrete - high loading capacity - rapid curing - large diameter applications - in service temperature range up to 80°C short term/50°C long term - manual cleaning for anchor size M8 to M16 and embedment depth $8d \leq h_{ef} \leq 10d$ - compressed air cleaning for anchor size M8 to M25 and embedment depth $8d \leq h_{ef} \leq 12d$



Concrete

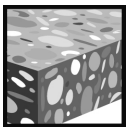

Small edge distance and spacing

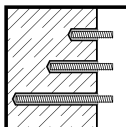

Variable embedment depth



Corrosion resistance



High corrosion resistance



Hilti Clean technology



European Technical Approval



CE conformity



PROFIS Anchor design software

Approvals / certificates

Description	Authority / Laboratory	No. / date of issue
European technical approval ^{a)}	CSTB, Paris	ETA-11/0354 / 2011-09-30

a) All data given in this section according ETA-11/0354 issue 2011-09-30.

Basic loading data (for a single anchor)

All data in this section applies to

For details see Simplified design method

- Correct setting (See setting instruction)
- No edge distance and spacing influence
- Steel failure
- Base material thickness, as specified in the table
- One typical embedment depth, as specified in the table
- One anchor material, as specified in the tables
- Concrete C 20/25, $f_{ck,cube} = 25 \text{ N/mm}^2$
- Temperate range I
(min. base material temperature -40°C , max. long term/short term base material temperature: $+24^\circ\text{C}/40^\circ\text{C}$)
- Installation temperature range -5°C to $+40^\circ\text{C}$

Embedment depth ^{a)} and base material thickness for the basic loading data. Mean ultimate resistance, characteristic resistance, design resistance, recommended loads.

Anchor size	M8	M10	M12	M16	M20	M24
Typical embedment depth h_{ef} [mm]	80	90	110	130	170	210
Base material thickness h [mm]	110	120	140	170	220	270

a) The allowed range of embedment depth is shown in the setting details. The corresponding load values can be calculated according to the simplified design method.

Mean ultimate resistance: non-cracked concrete C 20/25 , anchor HIT-V 5.8

Anchor size	M8	M10	M12	M16	M20	M24
Tensile $N_{R_{u,m}}$ HIT-V 5.8 [kN]	18,9	30,5	44,1	87,1	135,3	190,0
Shear $V_{R_{u,m}}$ HIT-V 5.8 [kN]	9,5	15,8	22,1	41,0	64,1	92,4

Characteristic resistance: non-cracked concrete C 20/25 , anchor HIT-V 5.8

Anchor size	M8	M10	M12	M16	M20	M24
Tensile N_{R_k} HIT-V 5.8 [kN]	18,0	29,0	42,0	65,3	101,5	142,5
Shear V_{R_k} HIT-V 5.8 [kN]	9,0	15,0	21,0	39,0	61,0	88,0

Design resistance: non-cracked concrete C 20/25 , anchor HIT-V 5.8

Anchor size	M8	M10	M12	M16	M20	M24
Tensile N_{R_d} HIT-V 5.8 [kN]	12,0	17,3	25,3	36,3	56,4	79,2
Shear V_{R_d} HIT-V 5.8 [kN]	7,2	12,0	16,8	31,2	48,8	70,4

Recommended loads ^{a)}: non-cracked concrete C 20/25 , anchor HIT-V 5.8

Anchor size	M8	M10	M12	M16	M20	M24
Tensile N_{rec} HIT-V 5.8 [kN]	8,6	12,3	18,1	25,9	40,3	56,5
Shear V_{rec} HIT-V 5.8 [kN]	5,1	8,6	12,0	22,3	34,9	50,3

a) With overall partial safety factor for action $\gamma = 1,4$. The partial safety factors for action depend on the type of loading and shall be taken from national regulations. According ETAG 001, annex C, the partial safety factor is $\gamma_G = 1,35$ for permanent actions and $\gamma_Q = 1,5$ for variable actions.

Service temperature range

Hilti HIT-CT 1 injection mortar may be applied in the temperature ranges given below. An elevated base material temperature may lead to a reduction of the design bond resistance.

Temperature range	Base material temperature	Maximum long term base material temperature	Maximum short term base material temperature
Temperature range I	-40 °C to +40 °C	+24 °C	+40 °C
Temperature range II	-40 °C to +80 °C	+50 °C	+80 °C

Max short term base material temperature

Short-term elevated base material temperatures are those that occur over brief intervals, e.g. as a result of diurnal cycling.

Max long term base material temperature

Long-term elevated base material temperatures are roughly constant over significant periods of time.

Materials

Mechanical properties of HIT-V

Anchor size			M8	M10	M12	M16	M20	M24
Nominal tensile strength f_{uk}	HIT-V(-F) 5.8	[N/mm ²]	500	500	500	500	500	500
	HIT-V(-F) 8.8	[N/mm ²]	800	800	800	800	800	800
	HIT-V -R	[N/mm ²]	700	700	700	700	700	700
	HIT-V -HCR	[N/mm ²]	800	800	800	800	800	700
Yield strength f_{yk}	HIT-V(-F) 5.8	[N/mm ²]	400	400	400	400	400	400
	HIT-V(-F) 8.8	[N/mm ²]	640	640	640	640	640	640
	HIT-V -R	[N/mm ²]	450	450	450	450	450	450
	HIT-V -HCR	[N/mm ²]	600	600	600	600	600	400
Stressed cross-section A_s	HIT-V	[mm ²]	36,6	58,0	84,3	157	245	353
Moment of resistance W	HIT-V	[mm ³]	31,2	62,3	109	277	541	935

Material quality

Part	Material
Threaded rod HIT-V(-F) 5.8	Strength class 5.8, A ₅ > 8% ductile steel galvanized ≥ 5 μm (-F) hot dipped galvanized ≥ 45 μm
Threaded rod HIT-V(-F) 8.8	Strength class 8.8, A ₅ > 8% ductile steel galvanized ≥ 5 μm (-F) hot dipped galvanized ≥ 45 μm (M8-M16 only)
Threaded rod HIT-V-R	Stainless steel grade A4, A ₅ > 8% ductile strength class 70 for ≤ M24 1.4401; 1.4404; 1.4578; 1.4571; 1.4439; 1.4362
Threaded rod HIT-V-HCR	High corrosion resistant steel, 1.4529; 1.4565 strength ≤ M20: R _m = 800 N/mm ² , R _{p0.2} = 640 N/mm ² , A ₅ > 8% ductile M24: R _m = 700 N/mm ² , R _{p0.2} = 400 N/mm ² , A ₅ > 8% ductile
Washer ISO 7089	Steel galvanized, hot dipped galvanized
	Stainless steel, 1.4401; 1.4404; 1.4578; 1.4571; 1.4439; 1.4362
	High corrosion resistant steel, 1.4529; 1.4565
Nut EN ISO 4032	Strength class 8 steel galvanized ≥ 5 μm hot dipped galvanized ≥ 45 μm
	Strength class 70, stainless steel grade A4, 1.4401; 1.4404; 1.4578; 1.4571; 1.4439; 1.4362
	Strength class 70, EN ISO 3506-2, high corrosion resistant steel, 1.4529; 1.4565

Anchor dimensions

Anchor size	M8	M10	M12	M16	M20	M24
Anchor rod HIT-V, HIT-V-F HIT-V-R, HIT-V-HCR	Anchor rods HIT-V (-F/ -R / -HCR) are available in variable length					

Setting instruction

Dry and water-saturated concrete, hammer drilling

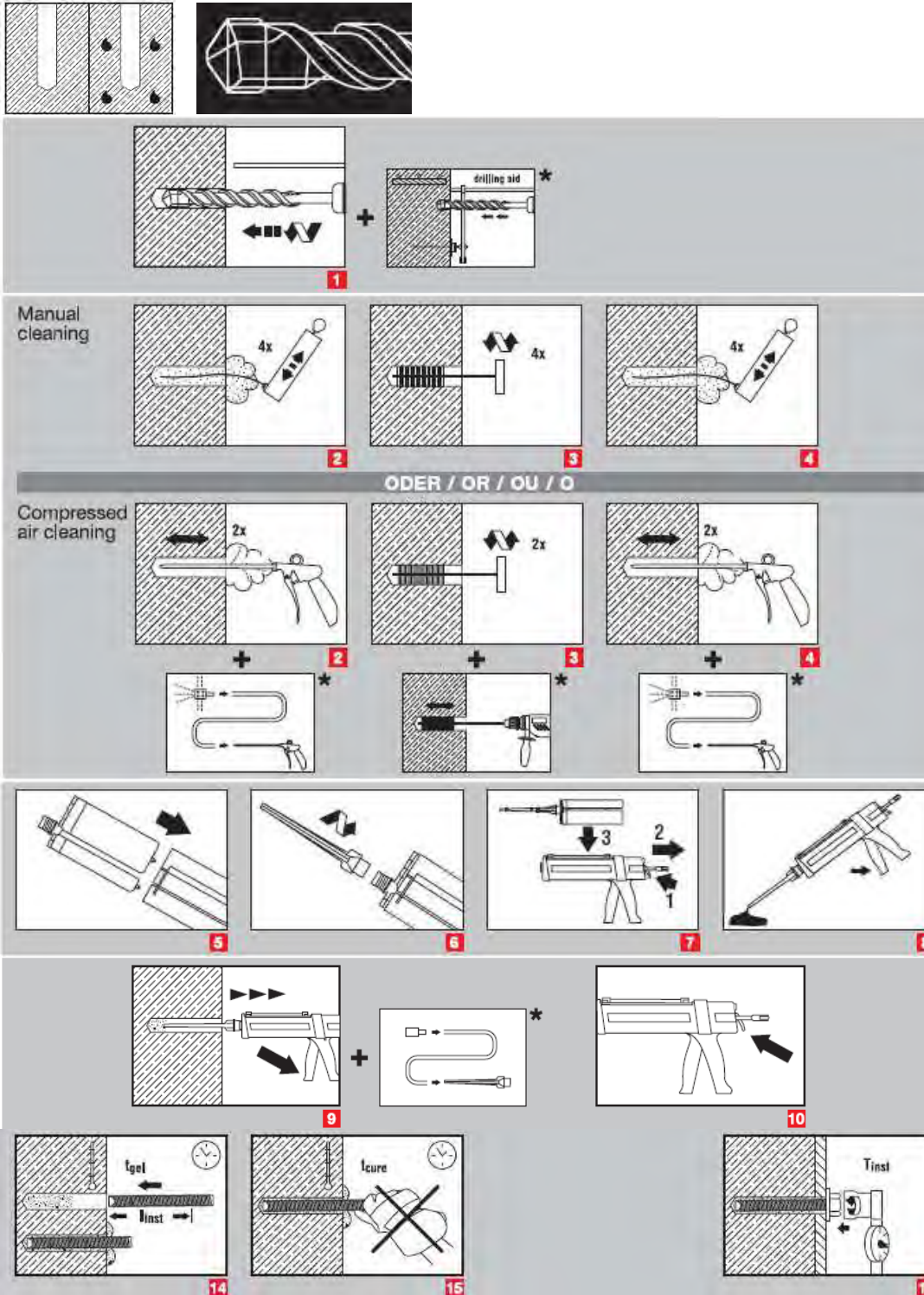

a)

b)

a) Note: Manual cleaning for element sizes $d \leq 16\text{mm}$ and embedment depth $h_{ef} \leq 10 d$ only!

b) Note: Extension and piston plug needed for overhead installation and/or embedment depth $> 250\text{mm}$!

For detailed information on installation see instruction for use given with the package of the product.

Working time, Curing time

Temperature of the base material T_{BM}	Working time t_{gel}	Curing time $t_{cure}^{a)}$
$-5\text{ °C} \leq T_{BM} < 0\text{ °C}$	60 min	6 h
$0\text{ °C} \leq T_{BM} < 5\text{ °C}$	40 min	3 h
$5\text{ °C} \leq T_{BM} < 10\text{ °C}$	25 min	2 h
$10\text{ °C} \leq T_{BM} < 20\text{ °C}$	10 min	90 min
$20\text{ °C} \leq T_{BM} < 30\text{ °C}$	4 min	75 min
$30\text{ °C} \leq T_{BM} \leq 40\text{ °C}$	2 min	60 min

a) The curing time data are valid for dry anchorage base only. For water saturated anchorage bases the curing times must be doubled.

Setting

installation equipment

Anchor size	M8	M10	M12	M16	M20	M24
Rotary hammer	TE 2 – TE 16				TE 40 – TE 70	
Other tools	compressed air gun or blow out pump, set of cleaning brushes, dispenser					

Setting details

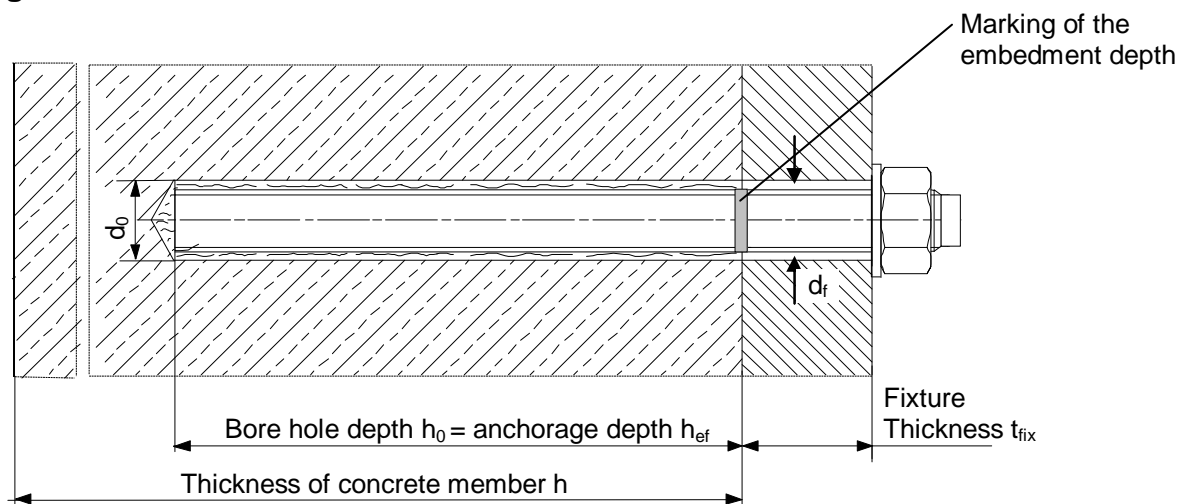

Setting details

Anchor size		M8	M10	M12	M16	M20	M24
Nominal diameter of drill bit	d_0 [mm]	10	12	14	18	22	28
Effective embedment and drill hole depth range ^{a)} for HIT-V	$h_{ef,min}$ [mm]	64	80	96	128	160	192
	$h_{ef,max}$ [mm]	96	120	144	192	240	288
Minimum base material thickness	h_{min} [mm]	$h_{ef} + 30 \text{ mm}$ $\geq 100 \text{ mm}$			$h_{ef} + 2 d_0$		
Diameter of clearance hole in the fixture	d_f [mm]	9	12	14	18	22	26
Torque moment	T_{max} ^{b)} [Nm]	10	20	40	80	150	200
Minimum spacing	s_{min} [mm]	40	50	60	80	100	120
Minimum edge distance	c_{min} [mm]	40	50	60	80	100	120
Critical spacing for splitting failure	$s_{cr,sp}$ [mm]	$2 c_{cr,sp}$					
Critical edge distance for splitting failure ^{c)}	$c_{cr,sp}$ [mm]	$1,0 \cdot h_{ef}$ for $h / h_{ef} \geq 2,0$					
		$4,6 h_{ef} - 1,8 h$ for $2,0 > h / h_{ef} > 1,3$					
		$2,26 h_{ef}$ for $h / h_{ef} \leq 1,3$					
Critical spacing for concrete cone failure	$s_{cr,N}$ [mm]	$2 c_{cr,N}$					
Critical edge distance for concrete cone failure ^{d)}	$c_{cr,N}$ [mm]	$1,5 h_{ef}$					

For spacing (or edge distance) smaller than critical spacing (or critical edge distance) the design loads have to be reduced.

- a) Embedment depth range: $h_{ef,min} \leq h_{ef} \leq h_{ef,max}$
- b) Maximum recommended torque moment to avoid splitting failure during installation with minimum spacing and/or edge distance.
- c) h : base material thickness ($h \geq h_{min}$), h_{ef} : embedment depth
- d) The critical edge distance for concrete cone failure depends on the embedment depth h_{ef} and the design bond resistance. The simplified formula given in this table is on the save side.

Simplified design method

Simplified version of the design method according ETAG 001, TR 029. Design resistance according data given in ETA-08/0341, issue 2008-12-02.

- Influence of concrete strength
- Influence of edge distance
- Influence of spacing
- Valid for a group of two anchors. (The method may also be applied for anchor groups with more than two anchors or more than one edge distance. The influencing factors must then be considered for each edge distance and spacing. The calculated design loads are then on the save side: They will be lower than the exact values according ETAG 001, TR 029. To avoid this, it is recommended to use the anchor design software PROFIS anchor)

The design method is based on the following simplification:

- No different loads are acting on individual anchors (no eccentricity)

The values are valid for one anchor.

For more complex fastening applications please use the anchor design software PROFIS Anchor.

Tension loading

The design tensile resistance is the lower value of

- Steel resistance: $N_{Rd,s}$
- Combined pull-out and concrete cone resistance: $N_{Rd,p} = N_{Rd,p}^0 \cdot f_{B,p} \cdot f_{1,N} \cdot f_{2,N} \cdot f_{3,N} \cdot f_{h,p} \cdot f_{re,N}$
- Concrete cone resistance: $N_{Rd,c} = N_{Rd,c}^0 \cdot f_B \cdot f_{1,N} \cdot f_{2,N} \cdot f_{3,N} \cdot f_{h,N} \cdot f_{re,N}$
- Concrete splitting resistance (only non-cracked concrete): $N_{Rd,sp} = N_{Rd,c}^0 \cdot f_B \cdot f_{1,sp} \cdot f_{2,sp} \cdot f_{3,sp} \cdot f_{h,N} \cdot f_{re,N}$

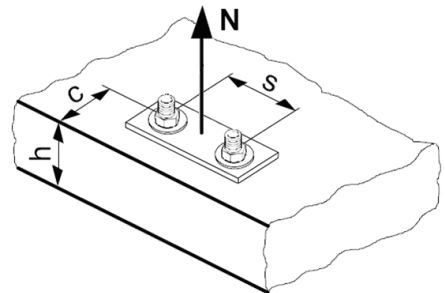

Basic design tensile resistance

Design steel resistance $N_{Rd,s}$

Anchor size		M8	M10	M12	M16	M20	M24
$N_{Rd,s}$	HIT-V(-F) 5.8 [kN]	12,0	19,3	28,0	52,7	82,0	118,0
	HIT-V(-F) 8.8 [kN]	19,3	30,7	44,7	84,0	130,7	188,0
	HIT-V-R [kN]	13,9	21,9	31,6	58,8	92,0	132,1
	HIT-V-HCR [kN]	19,3	30,7	44,7	84,0	130,7	117,6

Design combined pull-out and concrete cone resistance

$$N_{Rd,p} = N_{Rd,p}^0 \cdot f_{B,p} \cdot f_{1,N} \cdot f_{2,N} \cdot f_{3,N} \cdot f_{h,p} \cdot f_{re,N}$$

Anchor size		M8	M10	M12	M16	M20	M24
Typical embedment depth $h_{ef} = h_{ef,typ}$ [mm]		80	90	110	130	170	210
$N_{Rd,p}^0$ Temperature range I [kN]		13,4	17,3	25,3	36,3	56,4	79,2
$N_{Rd,p}^0$ Temperature range II [kN]		12,3	17,3	23,0	34,5	53,4	74,8

Design concrete cone resistance $N_{Rd,c} = N_{Rd,c}^0 \cdot f_B \cdot f_{1,N} \cdot f_{2,N} \cdot f_{3,N} \cdot f_{h,N} \cdot f_{re,N}$

Design splitting resistance $N_{Rd,sp} = N_{Rd,c}^0 \cdot f_B \cdot f_{1,sp} \cdot f_{2,sp} \cdot f_{3,sp} \cdot f_{h,N} \cdot f_{re,N}$

Anchor size		M8	M10	M12	M16	M20	M24
$N_{Rd,c}^0$	[kN]	20,1	24,0	32,4	41,6	62,2	85,4

Influencing factors

Influence of concrete strength on combined pull-out and concrete cone resistance

Concrete strength designation (ENV 206)	C 20/25	C 25/30	C 30/37	C 35/45	C 40/50	C 45/55	C 50/60
$f_{B,p} = (f_{ck,cube}/25N/mm^2)^{0,15}$ a)	1,00	1,03	1,06	1,09	1,11	1,13	1,14

a) $f_{ck,cube}$ = concrete compressive strength, measured on cubes with 150 mm side length

Influence of embedment depth on combined pull-out and concrete cone resistance

$$f_{h,p} = h_{ef}/h_{ef,typ}$$

Influence of concrete strength on concrete cone resistance

Concrete strength designation (ENV 206)	C 20/25	C 25/30	C 30/37	C 35/45	C 40/50	C 45/55	C 50/60
$f_B = (f_{ck,cube}/25N/mm^2)^{0,5}$ a)	1	1,1	1,22	1,34	1,41	1,48	1,55

a) $f_{ck,cube}$ = concrete compressive strength, measured on cubes with 150 mm side length

Influence of edge distance a)

$c/c_{cr,N}$	0,1	0,2	0,3	0,4	0,5	0,6	0,7	0,8	0,9	1
$c/c_{cr,sp}$										
$f_{1,N} = 0,7 + 0,3 \cdot c/c_{cr,N} \leq 1$	0,73	0,76	0,79	0,82	0,85	0,88	0,91	0,94	0,97	1
$f_{1,sp} = 0,7 + 0,3 \cdot c/c_{cr,sp} \leq 1$										
$f_{2,N} = 0,5 \cdot (1 + c/c_{cr,N}) \leq 1$	0,55	0,60	0,65	0,70	0,75	0,80	0,85	0,90	0,95	1
$f_{2,sp} = 0,5 \cdot (1 + c/c_{cr,sp}) \leq 1$										

a) The edge distance shall not be smaller than the minimum edge distance c_{min} . These influencing factors must be considered for every edge distance smaller than the critical edge distance.

Influence of anchor spacing a)

$s/s_{cr,N}$	0,1	0,2	0,3	0,4	0,5	0,6	0,7	0,8	0,9	1
$s/s_{cr,sp}$										
$f_{3,N} = 0,5 \cdot (1 + s/s_{cr,N}) \leq 1$	0,55	0,60	0,65	0,70	0,75	0,80	0,85	0,90	0,95	1
$f_{3,sp} = 0,5 \cdot (1 + s/s_{cr,sp}) \leq 1$										

a) The anchor spacing shall not be smaller than the minimum anchor spacing s_{min} . This influencing factor must be considered for every anchor spacing.

Influence of embedment depth on concrete cone resistance

$$f_{h,N} = (h_{ef}/h_{ef,typ})^{1,5}$$

Influence of reinforcement

h_{ef} [mm]	40	50	60	70	80	90	≥ 100
$f_{re,N} = 0,5 + h_{ef}/200\text{mm} \leq 1$	0,7 ^{a)}	0,75 ^{a)}	0,8 ^{a)}	0,85 ^{a)}	0,9 ^{a)}	0,95 ^{a)}	1

a) This factor applies only for dense reinforcement. If in the area of anchorage there is reinforcement with a spacing ≥ 150 mm (any diameter) or with a diameter ≤ 10 mm and a spacing ≥ 100 mm, then a factor $f_{re,N} = 1$ may be applied.

Shear loading

The design shear resistance is the lower value of

- Steel resistance: $V_{Rd,s}$
- Concrete pryout resistance: $V_{Rd,cp} = k \cdot \text{lower value of } N_{Rd,p} \text{ and } N_{Rd,c}$
- Concrete edge resistance: $V_{Rd,c} = V_{Rd,c}^0 \cdot f_B \cdot f_h \cdot f_4 \cdot f_{hef} \cdot f_c$

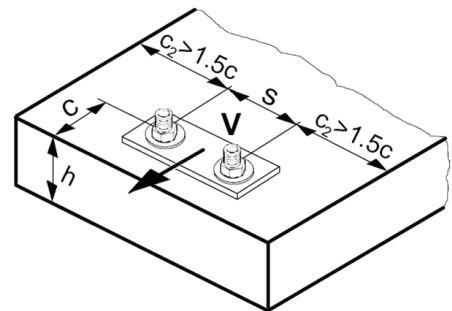

Basic design shear resistance

Design steel resistance $V_{Rd,s}$

Anchor size		M8	M10	M12	M16	M20	M24
$V_{Rd,s}$	HIT-V(-F) 5.8 [kN]	7,2	12,0	16,8	31,2	48,8	70,4
	HIT-V(-F) 8.8 [kN]	12,0	18,4	27,2	50,4	78,4	112,8
	HIT-V-R [kN]	8,3	12,8	19,2	35,3	55,1	79,5
	HIT-V-HCR [kN]	12,0	18,4	27,2	50,4	78,4	70,9

Design concrete pryout resistance $V_{Rd,cp} = \text{lower value}^a)$ of $k \cdot N_{Rd,p}$ and $k \cdot N_{Rd,c}$

$$k = 2 \text{ for } h_{ef} \geq 60 \text{ mm}$$

- a) $N_{Rd,p}$: Design combined pull-out and concrete cone resistance
 $N_{Rd,c}$: Design concrete cone resistance

Design concrete edge resistance $V_{Rd,c} = V_{Rd,c}^0 \cdot f_B \cdot f_h \cdot f_4 \cdot f_{hef} \cdot f_c$

Anchor size		M8	M10	M12	M16	M20	M24
Non-cracked concrete							
$V_{Rd,c}^0$ [kN]		5,9	8,6	11,6	18,7	27,0	36,6

Influencing factors

Influence of concrete strength

Concrete strength designation (ENV 206)	C 20/25	C 25/30	C 30/37	C 35/45	C 40/50	C 45/55	C 50/60
$f_B = (f_{ck,cube}/25\text{N/mm}^2)^{1/2}$ a)	1	1,1	1,22	1,34	1,41	1,48	1,55

- a) $f_{ck,cube}$ = concrete compressive strength, measured on cubes with 150 mm side length

Influence of angle between load applied and the direction perpendicular to the free edge

Angle β	0°	10°	20°	30°	40°	50°	60°	70°	80°	≥ 90°
f_{β}	1	1,01	1,05	1,13	1,24	1,40	1,64	1,97	2,32	2,50

Influence of base material thickness

h/c	0,15	0,3	0,45	0,6	0,75	0,9	1,05	1,2	1,35	≥ 1,5
$f_h = \{h/(1,5 \cdot c)\}^{1/2} \leq 1$	0,32	0,45	0,55	0,63	0,71	0,77	0,84	0,89	0,95	1,00

Influence of anchor spacing and edge distance ^{a)} for concrete edge resistance: f_4

$$f_4 = (c/h_{ef})^{1,5} \cdot (1 + s / [3 \cdot c]) \cdot 0,5$$

c/h_{ef}	Single anchor	Group of two anchors s/h_{ef}														
		0,75	1,50	2,25	3,00	3,75	4,50	5,25	6,00	6,75	7,50	8,25	9,00	9,75	10,50	11,25
0,50	0,35	0,27	0,35	0,35	0,35	0,35	0,35	0,35	0,35	0,35	0,35	0,35	0,35	0,35	0,35	0,35
0,75	0,65	0,43	0,54	0,65	0,65	0,65	0,65	0,65	0,65	0,65	0,65	0,65	0,65	0,65	0,65	0,65
1,00	1,00	0,63	0,75	0,88	1,00	1,00	1,00	1,00	1,00	1,00	1,00	1,00	1,00	1,00	1,00	1,00
1,25	1,40	0,84	0,98	1,12	1,26	1,40	1,40	1,40	1,40	1,40	1,40	1,40	1,40	1,40	1,40	1,40
1,50	1,84	1,07	1,22	1,38	1,53	1,68	1,84	1,84	1,84	1,84	1,84	1,84	1,84	1,84	1,84	1,84
1,75	2,32	1,32	1,49	1,65	1,82	1,98	2,15	2,32	2,32	2,32	2,32	2,32	2,32	2,32	2,32	2,32
2,00	2,83	1,59	1,77	1,94	2,12	2,30	2,47	2,65	2,83	2,83	2,83	2,83	2,83	2,83	2,83	2,83
2,25	3,38	1,88	2,06	2,25	2,44	2,63	2,81	3,00	3,19	3,38	3,38	3,38	3,38	3,38	3,38	3,38
2,50	3,95	2,17	2,37	2,57	2,77	2,96	3,16	3,36	3,56	3,76	3,95	3,95	3,95	3,95	3,95	3,95
2,75	4,56	2,49	2,69	2,90	3,11	3,32	3,52	3,73	3,94	4,15	4,35	4,56	4,56	4,56	4,56	4,56
3,00	5,20	2,81	3,03	3,25	3,46	3,68	3,90	4,11	4,33	4,55	4,76	4,98	5,20	5,20	5,20	5,20
3,25	5,86	3,15	3,38	3,61	3,83	4,06	4,28	4,51	4,73	4,96	5,18	5,41	5,63	5,86	5,86	5,86
3,50	6,55	3,51	3,74	3,98	4,21	4,44	4,68	4,91	5,14	5,38	5,61	5,85	6,08	6,31	6,55	6,55
3,75	7,26	3,87	4,12	4,36	4,60	4,84	5,08	5,33	5,57	5,81	6,05	6,29	6,54	6,78	7,02	7,26
4,00	8,00	4,25	4,50	4,75	5,00	5,25	5,50	5,75	6,00	6,25	6,50	6,75	7,00	7,25	7,50	7,75
4,25	8,76	4,64	4,90	5,15	5,41	5,67	5,93	6,18	6,44	6,70	6,96	7,22	7,47	7,73	7,99	8,25
4,50	9,55	5,04	5,30	5,57	5,83	6,10	6,36	6,63	6,89	7,16	7,42	7,69	7,95	8,22	8,49	8,75
4,75	10,35	5,45	5,72	5,99	6,27	6,54	6,81	7,08	7,36	7,63	7,90	8,17	8,45	8,72	8,99	9,26
5,00	11,18	5,87	6,15	6,43	6,71	6,99	7,27	7,55	7,83	8,11	8,39	8,66	8,94	9,22	9,50	9,78
5,25	12,03	6,30	6,59	6,87	7,16	7,45	7,73	8,02	8,31	8,59	8,88	9,17	9,45	9,74	10,02	10,31
5,50	12,90	6,74	7,04	7,33	7,62	7,92	8,21	8,50	8,79	9,09	9,38	9,67	9,97	10,26	10,55	10,85

a) The anchor spacing and the edge distance shall not be smaller than the minimum anchor spacing s_{min} and the minimum edge distance c_{min} .

Influence of embedment depth

h_{ef}/d	4	4,5	5	6	7	8	9	10	11
$f_{hef} = 0,05 \cdot (h_{ef} / d)^{1,68}$	0,51	0,63	0,75	1,01	1,31	1,64	2,00	2,39	2,81

h_{ef}/d	12	13	14	15	16	17	18	19	20
$f_{hef} = 0,05 \cdot (h_{ef} / d)^{1,68}$	3,25	3,72	4,21	4,73	5,27	5,84	6,42	7,04	7,67

Influence of edge distance ^{a)}

c/d	4	6	8	10	15	20	30	40
$f_c = (d / c)^{0,19}$	0,77	0,71	0,67	0,65	0,60	0,57	0,52	0,50

a) The edge distance shall not be smaller than the minimum edge distance c_{min} .

Combined tension and shear loading

For combined tension and shear loading see section “Anchor Design”.

Precalculated values – design resistance values

All data applies to:

- non-cracked concrete C 20/25 – $f_{ck,cube} = 25 \text{ N/mm}^2$
- temperature range I (see Service temperature range)
- minimum thickness of base material
- no effects of dense reinforcement

Recommended loads can be calculated by dividing the design resistance by an overall partial safety factor for action $\gamma = 1,4$. The partial safety factors for action depend on the type of loading and shall be taken from national regulations.

Design resistance: concrete C 20/25 – $f_{ck,cube} = 25 \text{ N/mm}^2$ - minimum embedment depth

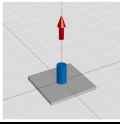
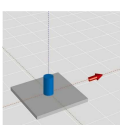
Anchor size	M8	M10	M12	M16	M20	M24
Embedment depth $h_{ef} = h_{ef,min}$ [mm]	64	80	96	128	160	192
Base material thickness $h = h_{min}$ [mm]	100	110	126	164	204	248
 Tensile N_{Rd}: single anchor, no edge effects						
HIT-V(-F) 5.8 HIT-V(-F) 8.8 HIT-V-R HIT-V-HCR [kN]	10,7	15,4	22,1	35,7	53,1	72,4
 Shear V_{Rd}: single anchor, no edge effects, without lever arm						
HIT-V(-F) 5.8 [kN]	7,2	12,0	16,8	31,2	48,8	70,4
HIT-V(-F) 8.8 [kN]	12,0	18,4	27,2	50,4	78,4	112,8
HIT-V-R [kN]	8,3	12,8	19,2	35,3	55,1	79,5
HIT-V-HCR [kN]	12,0	18,4	27,2	50,4	78,4	70,9

Design resistance: concrete C 20/25 – $f_{ck,cube} = 25 \text{ N/mm}^2$ - minimum embedment depth

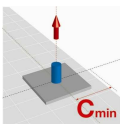
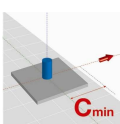
Anchor size	M8	M10	M12	M16	M20	M24
Embedment depth $h_{ef} = h_{ef,min}$ [mm]	64	80	96	128	160	192
Base material thickness $h = h_{min}$ [mm]	100	110	126	164	204	248
Edge distance $c = c_{min}$ [mm]	40	50	60	80	100	120
 Tensile N_{Rd}: single anchor, min. edge distance ($c = c_{min}$)						
HIT-V(-F) 5.8 HIT-V(-F) 8.8 HIT-V-R HIT-V-HCR [kN]	6,3	9,0	12,9	21,3	31,9	43,6
 Shear V_{Rd}: single anchor, min. edge distance ($c = c_{min}$), without lever arm						
HIT-V(-F) 5.8 HIT-V(-F) 8.8 HIT-V-R HIT-V-HCR [kN]	3,6	5,2	7,1	11,6	16,9	23,0

**Design resistance: concrete C 20/25 – $f_{ck,cube} = 25 \text{ N/mm}^2$ - minimum embedment depth
(load values are valid for single anchor)**

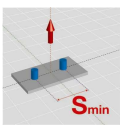
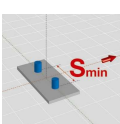
Anchor size	M8	M10	M12	M16	M20	M24
Embedment depth $h_{ef} = h_{ef,min}$ [mm]	64	80	96	128	160	192
Base material thickness $h = h_{min}$ [mm]	100	110	126	164	204	248
Spacing $s = s_{min}$ [mm]	40	50	60	80	100	120
 Tensile N_{Rd}: double anchor, no edge effects, min. spacing ($s = s_{min}$)						
HIT-V(-F) 5.8 HIT-V(-F) 8.8 HIT-V-R HIT-V-HCR [kN]	7,0	10,0	14,0	22,6	33,1	44,8
 Shear V_{Rd}: double anchor, no edge effects, min. spacing ($s = s_{min}$), without lever arm						
HIT-V(-F) 5.8 [kN]	7,2	12,0	16,8	31,2	48,8	70,4
HIT-V(-F) 8.8 [kN]	12,0	18,4	26,7	43,2	64,1	87,5
HIT-V-R [kN]	8,3	12,8	19,2	35,3	55,1	79,5
HIT-V-HCR [kN]	12,0	18,4	26,7	43,2	64,1	70,9

Design resistance: concrete C 20/25 – $f_{ck,cube} = 25 \text{ N/mm}^2$ - typical embedment depth

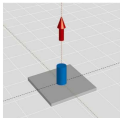
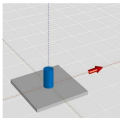
Anchor size	M8	M10	M12	M16	M20	M24	
Embedment depth $h_{ef} = h_{ef,typ}$ [mm]	80	90	110	130	170	210	
Base material thickness $h = h_{min}$ [mm]	110	120	140	166	214	266	
	Tensile N_{Rd}: single anchor, no edge effects						
	HIT-V(-F) 5.8 [kN]	12,0	17,3	25,3	36,3	56,4	79,2
	HIT-V(-F) 8.8 [kN]	13,4	17,3	25,3	36,3	56,4	79,2
	HIT-V-R HIT-V-HCR						
	Shear V_{Rd}: single anchor, no edge effects, without lever arm						
	HIT-V(-F) 5.8 [kN]	7,2	12,0	16,8	31,2	48,8	70,4
	HIT-V(-F) 8.8 [kN]	12,0	18,4	27,2	50,4	78,4	112,8
	HIT-V-R [kN]	8,3	12,8	19,2	35,3	55,1	79,5
	HIT-V-HCR [kN]	12,0	18,4	27,2	50,4	78,4	70,9

Design resistance: concrete C 20/25 – $f_{ck,cube} = 25 \text{ N/mm}^2$ - typical embedment depth

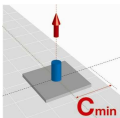
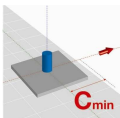
Anchor size	M8	M10	M12	M16	M20	M24	
Embedment depth $h_{ef} = h_{ef,typ}$ [mm]	80	90	110	130	170	210	
Base material thickness $h = h_{min}$ [mm]	110	120	140	166	214	266	
Edge distance $c = c_{min}$ [mm]	40	50	60	80	100	120	
	Tensile N_{Rd}: single anchor, min. edge distance ($c = c_{min}$)						
	HIT-V(-F) 5.8 [kN]	7,7	10,1	14,7	21,6	33,9	48,0
	HIT-V(-F) 8.8 [kN]						
	HIT-V-R HIT-V-HCR						
	Shear V_{Rd}: single anchor, min. edge distance ($c = c_{min}$), without lever arm						
	HIT-V(-F) 5.8 [kN]	3,7	5,3	7,3	11,6	17,2	23,6
	HIT-V(-F) 8.8 [kN]						
	HIT-V-R [kN]						
	HIT-V-HCR [kN]						

**Design resistance: concrete C 20/25 – $f_{ck,cube} = 25 \text{ N/mm}^2$ - typical embedment depth
(load values are valid for single anchor)**

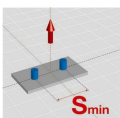
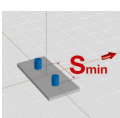
Anchor size	M8	M10	M12	M16	M20	M24	
Embedment depth $h_{ef} = h_{ef,typ}$ [mm]	80	90	110	130	170	210	
Base material thickness $h = h_{min}$ [mm]	110	120	140	166	214	266	
Spacing s [mm]	40	50	60	80	100	120	
	Tensile N_{Rd}: double anchor, no edge effects, min. spacing ($s = s_{min}$)						
	HIT-V(-F) 5.8 [kN]	8,9	11,3	16,3	23,0	35,4	49,7
	HIT-V(-F) 8.8 [kN]						
	HIT-V-R HIT-V-HCR						
	Shear V_{Rd}: double anchor, no edge effects, min. spacing ($s = s_{min}$), without lever arm						
	HIT-V(-F) 5.8 [kN]	7,2	12,0	16,8	31,2	48,8	70,4
	HIT-V(-F) 8.8 [kN]	12,0	18,4	27,2	43,7	67,4	94,2
	HIT-V-R [kN]	8,3	12,8	19,2	35,3	55,1	79,5
	HIT-V-HCR [kN]	12,0	18,4	27,2	43,7	67,4	70,9

Design resistance: concrete C 20/25 – $f_{ck,cube} = 25 \text{ N/mm}^2$ - embedment depth = 12 d^{a)}

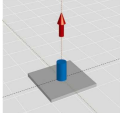
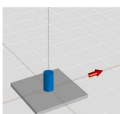
Anchor size	M8	M10	M12	M16	M20	M24
Embedment depth $h_{ef} = 12 d^a)$ [mm]	96	120	144	192	240	288
Base material thickness $h = h_{min}$ [mm]	126	150	174	228	288	344
 Tensile N_{Rd}: single anchor, no edge effects						
HIT-V(-F) 5.8 [kN]	12,0	19,3	28,0	52,7	79,6	108,6
HIT-V(-F) 8.8 [kN]	16,1	23,0	33,2	53,6	79,6	108,6
HIT-V-R [kN]	13,9	21,9	31,6	53,6	79,6	108,6
HIT-V-HCR [kN]	16,1	23,0	33,2	53,6	79,6	108,6
 Shear V_{Rd}: single anchor, no edge effects, without lever arm						
HIT-V(-F) 5.8 [kN]	7,2	12,0	16,8	31,2	48,8	70,4
HIT-V(-F) 8.8 [kN]	12,0	18,4	27,2	50,4	78,4	112,8
HIT-V-R [kN]	8,3	12,8	19,2	35,3	55,1	79,5
HIT-V-HCR [kN]	12,0	18,4	27,2	50,4	78,4	70,9

a) d = element diameter

Design resistance: concrete C 20/25 – $f_{ck,cube} = 25 \text{ N/mm}^2$ - embedment depth = 12 d^{a)}

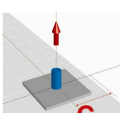
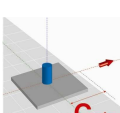
Anchor size	M8	M10	M12	M16	M20	M24
Embedment depth $h_{ef} = 12 d^a)$ [mm]	96	120	144	192	240	288
Base material thickness $h = h_{min}$ [mm]	126	150	174	228	284	344
Edge distance $c = c_{min}$ [mm]	40	50	60	80	100	120
 Tensile N_{Rd}: single anchor, min. edge distance ($c = c_{min}$)						
HIT-V(-F) 5.8 [kN]	9,2	13,4	19,3	31,9	47,9	66,2
HIT-V(-F) 8.8						
HIT-V-R						
HIT-V-HCR						
 Shear V_{Rd}: single anchor, min. edge distance ($c = c_{min}$), without lever arm						
HIT-V(-F) 5.8 [kN]	3,9	5,7	7,8	12,9	18,9	25,9
HIT-V(-F) 8.8						
HIT-V-R						
HIT-V-HCR						

a) d = element diameter

Design resistance: concrete C 20/25 – $f_{ck,cube} = 25 \text{ N/mm}^2$ - embedment depth = 12 d^{a)}
(load values are valid for single anchor)

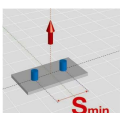
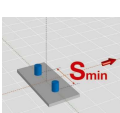
Anchor size	M8	M10	M12	M16	M20	M24
Embedment depth $h_{ef} = 12 d^a)$ [mm]	96	120	144	192	240	288
Base material thickness $h = h_{min}$ [mm]	126	150	174	228	284	344
Spacing $s = s_{min}$ [mm]	40	50	60	80	100	120
 Tensile N_{Rd}: double anchor, no edge effects, min. spacing ($s = s_{min}$)						
HIT-V(-F) 5.8 [kN]	10,8	15,5	22,0	35,4	52,1	70,9
HIT-V(-F) 8.8						
HIT-V-R						
HIT-V-HCR						
 Shear V_{Rd}: double anchor, no edge effects, min. spacing ($s = s_{min}$), without lever arm						
HIT-V(-F) 5.8 [kN]	7,2	12,0	16,8	31,2	48,8	70,4
HIT-V(-F) 8.8 [kN]						
HIT-V-R [kN]						
HIT-V-HCR [kN]						

a) d = element diameter

